

型号规格

SH40N - E 25 LR1 - M18

① ② ③ ④ ⑤

① 吸盘型号	② 缓冲形式	③ 缓冲行程		⑤ 安装规格
SH40N	E- 外置弹簧	25	75	M18- M18x1.5
		50	100	M22- M22x1.5
④ 真空口方向				
空白 - 垂直方向,Rc1/8内螺纹		M18- M18x1.5		
LR1 - 水平方向,Rc1/8内螺纹		M22- M22x1.5		



◇注:吸盘选型请参考样本185页

选型规格

型号	缓冲行程				安装规格	
	25	50	75	100	M18	M22
SH40 - 80	●	●	●	-	●	-
SH100 - 125	●	●	●	●	-	●

◇注:"●"表示默认规格,常备库存,货期短;"-"表示不可选。特殊定制请咨询销售客服。

尺寸规格(mm)

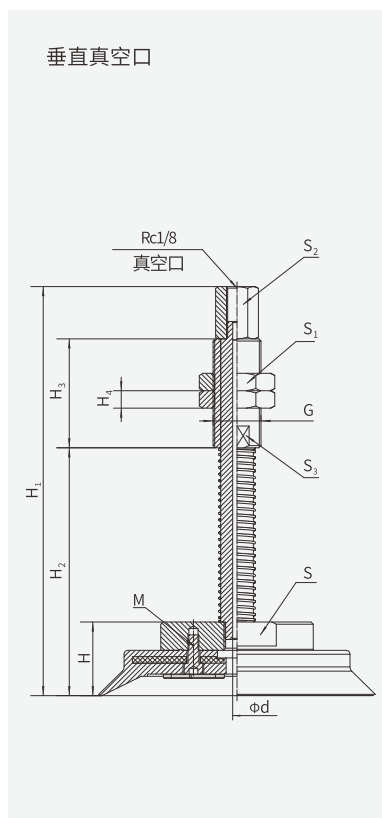

型号/尺寸	H	H ₁	H ₂	H ₃	H ₄	d	G	M	S	S ₁	S ₂	S ₃
SH40-E25-M18	23	118.5	63	35	6	3	M18×1.5	3-M3	24	27	14	16
SH40-E50-M18	23	153.5	98	35	6	3	M18×1.5	3-M3	24	27	14	16
SH40-E75-M18	23	189.5	134	35	6	3	M18×1.5	3-M3	24	27	14	16
SH50-E25-M18	23	118.5	63	35	6	3	M18×1.5	3-M3	24	27	14	16
SH50-E50-M18	23	153.5	98	35	6	3	M18×1.5	3-M3	24	27	14	16
SH50-E75-M18	23	189.5	134	35	6	3	M18×1.5	3-M3	24	27	14	16
SH63-E25-M18	26	121.5	66	35	6	3	M18×1.5	4-M4	37	27	14	16
SH63-E50-M18	26	156.5	101	35	6	3	M18×1.5	4-M4	37	27	14	16
SH63-E75-M18	26	192.5	137	35	6	3	M18×1.5	4-M4	37	27	14	16
SH80-E25-M18	28	123.5	68	35	6	3	M18×1.5	4-M4	37	27	14	16
SH80-E50-M18	28	158.5	103	35	6	3	M18×1.5	4-M4	37	27	14	16
SH80-E75-M18	28	194.5	139	35	6	3	M18×1.5	4-M4	37	27	14	16
SH100-E25-M22	34	152	78	50	8	4	M22×1.5	4-M5	60	30	17	19
SH100-E50-M22	34	188	114	50	8	4	M22×1.5	4-M5	60	30	17	19
SH100-E75-M22	34	228	154	50	8	4	M22×1.5	4-M5	60	30	17	19
SH100-E100-M22	34	263	189	50	8	4	M22×1.5	4-M5	60	30	17	19
SH125-E25-M22	34	152	78	50	8	4	M22×1.5	4-M5	60	30	17	19
SH125-E50-M22	34	188	114	50	8	4	M22×1.5	4-M5	60	30	17	19
SH125-E75-M22	34	228	154	50	8	4	M22×1.5	4-M5	60	30	17	19
SH125-E100-M22	34	263	189	50	8	4	M22×1.5	4-M5	60	30	17	19

尺寸规格(mm)

水平真空口

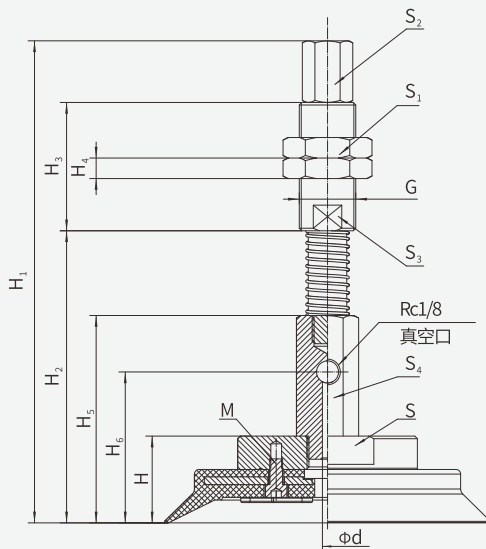

型号/尺寸	H	H ₁	H ₂	H ₃	H ₄	H ₅	H ₆	d	G	M	S	S ₁	S ₂	S ₃	S ₄
SH40-E25LR1-M18	23	151	100	35	6	60	38	3	M18×1.5	3-M3	24	27	14	16	21
SH40-E50LR1-M18	23	186	135	35	6	60	38	3	M18×1.5	3-M3	24	27	14	16	21
SH40-E75LR1-M18	23	222	171	35	6	60	38	3	M18×1.5	3-M3	24	27	14	16	21
SH50-E25LR1-M18	23	151	100	35	6	60	38	3	M18×1.5	3-M3	24	27	14	16	21
SH50-E50LR1-M18	23	186	135	35	6	60	38	3	M18×1.5	3-M3	24	27	14	16	21
SH50-E75LR1-M18	23	222	171	35	6	60	38	3	M18×1.5	3-M3	24	27	14	16	21
SH63-E25LR1-M18	26	154	103	35	6	63	41	3	M18×1.5	4-M4	37	27	14	16	21
SH63-E50LR1-M18	26	189	136	35	6	63	41	3	M18×1.5	4-M4	37	27	14	16	21
SH63-E75LR1-M18	26	225	172	35	6	63	41	3	M18×1.5	4-M4	37	27	14	16	21
SH80-E25LR1-M18	28	156	105	35	6	63	41	3	M18×1.5	4-M4	37	27	14	16	21
SH80-E50LR1-M18	28	191	138	35	6	63	41	3	M18×1.5	4-M4	37	27	14	16	21
SH80-E75LR1-M18	28	227	174	35	6	63	41	3	M18×1.5	4-M4	37	27	14	16	21
SH100-E25LR1-M22	34	186	115	50	8	71	49	4	M22×1.5	4-M5	60	30	17	19	21
SH100-E50LR1-M22	34	222	151	50	8	71	49	4	M22×1.5	4-M5	60	30	17	19	21
SH100-E75LR1-M22	34	262	191	50	8	71	49	4	M22×1.5	4-M5	60	30	17	19	21
SH100-E100LR1-M22	34	297	226	50	8	71	49	4	M22×1.5	4-M5	60	30	17	19	21
SH125-E25LR1-M22	34	186	115	50	8	71	49	4	M22×1.5	4-M5	60	30	17	19	21
SH125-E50LR1-M22	34	222	151	50	8	71	49	4	M22×1.5	4-M5	60	30	17	19	21
SH125-E75LR1-M22	34	262	191	50	8	71	49	4	M22×1.5	4-M5	60	30	17	19	21
SH125-E100LR1-M22	34	297	226	50	8	71	49	4	M22×1.5	4-M5	60	30	17	19	21

SB

SBA

SBB

SBF

SBOF

SFT

SFA

STP

SBL

SBLP

SBS

SF

SU

SUF

SFG

SFU

STC

SFF

SFM

SDM

SHT

SOFA

SOB

SOF

SOG

SFP

SBP

SXP

SGP

SDL

SH

SHB

SZ

SAN

SAO

SPA

SPC

SPF

SPJ

SPU

SNP

SOP